

# HE Auto-Wah

HE's auto-effect takes the work out of wah-wah.

Steve Giles

IT IS some sixteen years since the first guitar processing units became available. Those first effects units paved the way for controlled distortion and sophisticated filtering systems. Eventually, the development of phasers and flangers, in the seventies, gave the musician versatility and control from circuitry entirely within the unit's case. Other effects, like the wah-wah pedal, have external controls (a foot pedal attached to a pot which sweeps the filter up and down). Phasers and flangers are voltage controlled, by a slow oscillator, to provide their characteristic cyclic sweeping effect. So, no matter how hard the strings are plucked, the sound processing remains the same. This led to a desire for some additional responsiveness and, towards the end of the 1970s, guitar processing units appeared which were triggered by command signals from the guitar. This is similar to the way synthesiser can trigger envelope generators when a key is played. Of course, in the case of a guitar, this occurs when a string is plucked. The HE Auto-Wah is one such 'guitar triggered' effects unit. It can be built for a fraction of the cost of similar commercial units and will process signals in a number of interesting ways.

The usual circuit for a device of this type first feeds the guitar signals through an envelope follower. This produces a DC voltage that corresponds to the overall amplitude of the output from the instrument — strumming harder produces a higher DC output voltage. This feeds a comparator which goes high when the envelope follower voltage exceeds a certain threshold. It then drops back to zero when the envelope drops below this threshold. However, there is a problem in the case of guitar notes. Although the initial peak of a note will be more than sufficient to trigger the comparator, as the amplitude falls, there may be one or two extra peaks among the generally decaying level. These cause the envelope voltage to momentarily rise and retrigger the comparator. This is illustrated in Figure 1 which shows two additional peaks after the envelope voltage has fallen below the comparator threshold. A considerable amount of circuitry is necessary to minimise such false triggering. Apart from being outside the scope of this article, it was not too much of a problem with our prototype unit, which simply used a high gain input amp to trigger a comparator. This allows the production of a new 'frequency-band' sweep each time a note is played (dependent on the

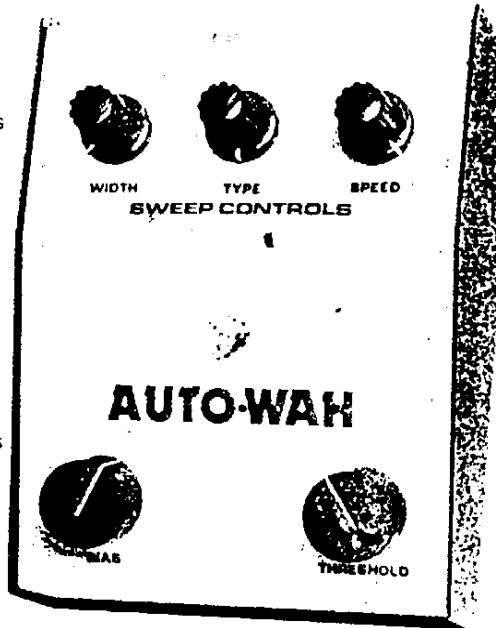

settings of the sweep controls), so long as you don't pick too quickly.

With such sudden changes of state — a high output or zero — it's important to ensure that a complete filter cycle sweeps smoothly across the frequency range. To do this we used a field effect transistor, as a variable resistor, to control a bridge-T filtering network around an op-amp. By carefully adjusting the threshold control, it's possible to play chords with virtually no false triggering and produce quite a deep wah-wah effect.

## Circuit Description

The circuit of Figure 2 has two basic sections, one consisting of 1C1, Q1 and Q2 to produce the control voltage,

and the other formed by IC2 and Q3 — the inverting bandpass filter. The signal is fed to IC1a, a non-inverting amplifier, whose gain is set at a high level by a large feedback resistor (R3). This ensures the unit functions properly from even low output guitars. The output from IC1a is then fed to pin 5 of IC1b via R4, where threshold control RV1 sets the point at which it will be triggered by IC1a. The output from the comparator is rectified by D1 and passed to emitter follower Q1 (via R6) after charging C4, which is in parallel with R15. When IC1b goes high, it is followed by Q1, providing a smooth charging action on C2 until the emitter voltage is attained. At this point, C2 discharges through R7, RV2 and RV3 to the 0 V rail. The voltage level for Q1 is set by RV2, since it controls the point at which C2 begins to discharge. The ramp voltage on C2 is fed to RV4 and also via R9 to an inverter, based around Q2. The inverted signal goes to the other end of RV4, which acts as a balance control to provide some control over the shape of the envelope. The voltage at RV4's wiper is then passed to the gate of Q3, a field effect transistor (FET), which operates as a part of the input, via C8 and R17. In this way the signal is band-pass filtered, with C5 and C6 chosen for optimum sound effect. These two capacitors determine which narrow band of the guitar signal is boosted. This band is moved up and down the audio spectrum by varying the drain-source resistance of Q3 — producing the familiar wah-wah effect. The voltage fed to Q3's gate is therefore affected by the setting of RV4, which sweeps the filter from the bass or treble end. Since this type of FET requires a control voltage negative to half the supply rail, the series combination of R14 and RV5 provide a bias to shift the gate voltage between 0 V and half the supply. Filter decoupling is provided by C7

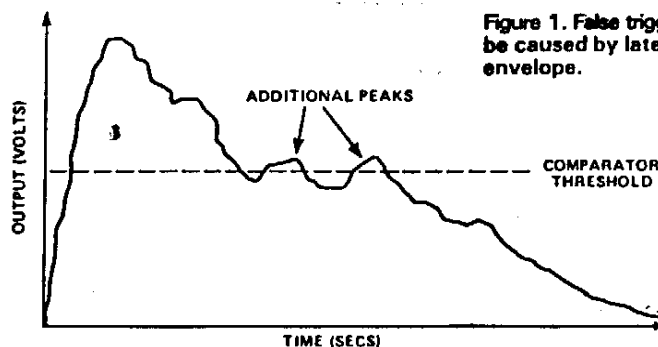

Figure 1. False triggering of an auto-wah can be caused by late peaks in the voltage envelope.

# Auto-Wah

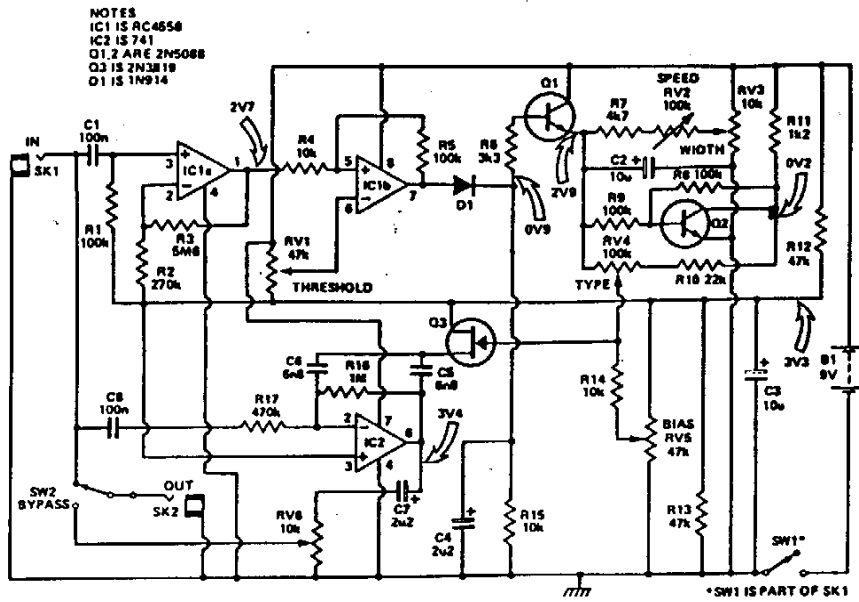

Figure 2. The complete Auto-Wah circuit with some typical DC voltages indicated. Note these measurements apply with no input signal applied.

and attenuated by RV6, allowing the output to match the input level. As a single-ended supply is used, R12 and R13 set the mid-supply voltage, which is by-passed by C3. Current consumption is rather high at 12.5 mA, so we recommend you use a long-life (alkaline) PP3 type battery for extended use.

### Construction

Referring to the component overlay diagram of Figure 3. Begin by soldering the two wire links and resistors. Next, the capacitors, making sure that correct polarities are observed for the tantalum types. Now, assemble the three transistors and the diode (D1). You must ensure these are placed with their leads in the proper positions. The diode must have its banded end (cathode) nearest R15. Transistor Q2 needs its base lead bent to fit the right

### Parts List

<b>RESISTORS (All 1/4 W, 5%, Carbon)</b>	
R1, 5, 8, 9	100k
R2	270k
R3	5M6
R4, 14, 15	10k
R6	3k3
R7	4k7
R10	22k
R11	1k2
R12, 13	47k
R16	1M
R17	470k
<b>POTENTIOMETERS</b>	
RV1, 5	47k linear carbon
RV2, 4	100k linear carbon
RV3	10k linear carbon
RV6	10k sub-miniature preset
<b>CAPACITORS</b>	
C1, 8	100n C280 polyester
C2, 3	10µ 10 V radial electrolytic
C4, 7	2µ2 10 V radial electrolytic
C5, 6	6n8 polycarbonate (metallised)
<b>SEMICONDUCTORS</b>	
IC1	RC4558 dual op-amp
IC2	741 op-amp
Q1, 2	2N5088 silicon NPN transistor
Q3	2N3819 N-channel FET
D1	1N914 silicon diode
<b>MISCELLANEOUS</b>	
SK1 (SW1)	1/4" jack socket with make contacts
SK2	1/4" jack socket
SW2	push-to-make switch
B1	PP3 9 V alkaline 'Long Life' Battery
Case (RS 508-201), PP3 battery clips, 8-pin DIL socket, collet knobs (3 off), shallow knobs (2 off), short standoffs (4 off), PCB, solder, wire, etc.	

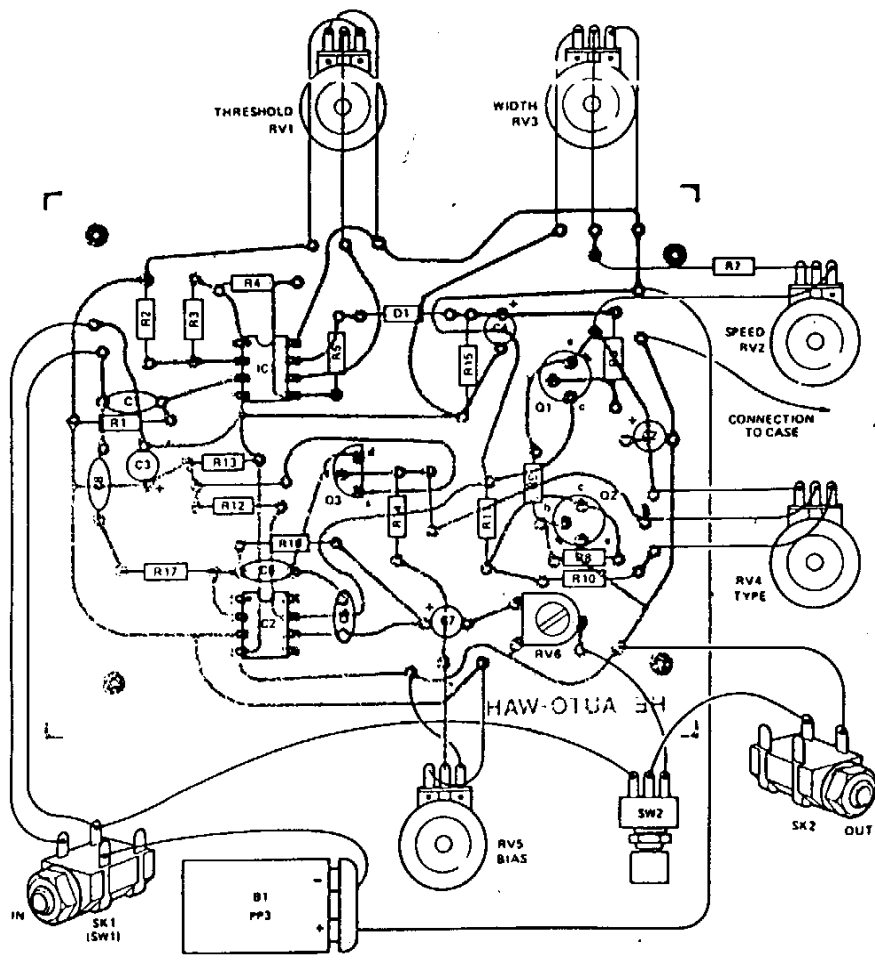

Figure 3. View from the component side of the PCB.

positions; the other two transistors fit without changing the position of any leads. The IC's are not fitted yet, but if you are using sockets these can be soldered into place, ready to take the IC's.

Lastly, wire up the five pots, two sockets and footswitch — don't forget the battery connector. The (red) positive wire from the connector, is soldered direct to the PCB. The negative (black) wire is taken to one earth tag on the input jack. The other earth tag is connected to the board so that the battery is only switched on when a jack-plug is inserted.

To make sure you have the leads connected to the right tags, put a standard jack-plug into the input socket. This should push the earth connector to link the two earth tags together. If your jack socket has 'break' rather than 'make' contacts, you will have to bend the short tag connector backwards and over the top of the other one. Of course, this is avoided if you buy a socket with 'make' contacts, in the first place.

When you have completed all the off-board wiring, it only remains to plug in the ICs and switch the unit on by inserting a jack-plug into the input socket. However, before starting to play with the effect, it's a good idea to check on some voltage readings. These are shown on the circuit diagram (Figure 2), and apply when no input signal is present. The control settings are as follows: RV1, RV4 and RV5 — full rotation; RV2 and RV3 midway along the track. It is essential you set the pots in this way, since some of them have a large effect on quiescent voltages. One final point to note is that readings must be taken using a high-impedance DC meter.

If everything seems OK, you can hook the output up to an amplifier and set RV4 for maximum downwards sweep. Pluck a string on your guitar gently, so as not to trigger the comparator, and set RV5 at the base end of the filter's passband. Now pluck the string hard and the filter should sweep from treble to bass.

Now try setting RV4 at the other end — this point may lie halfway along its track. You will then hear the pass-

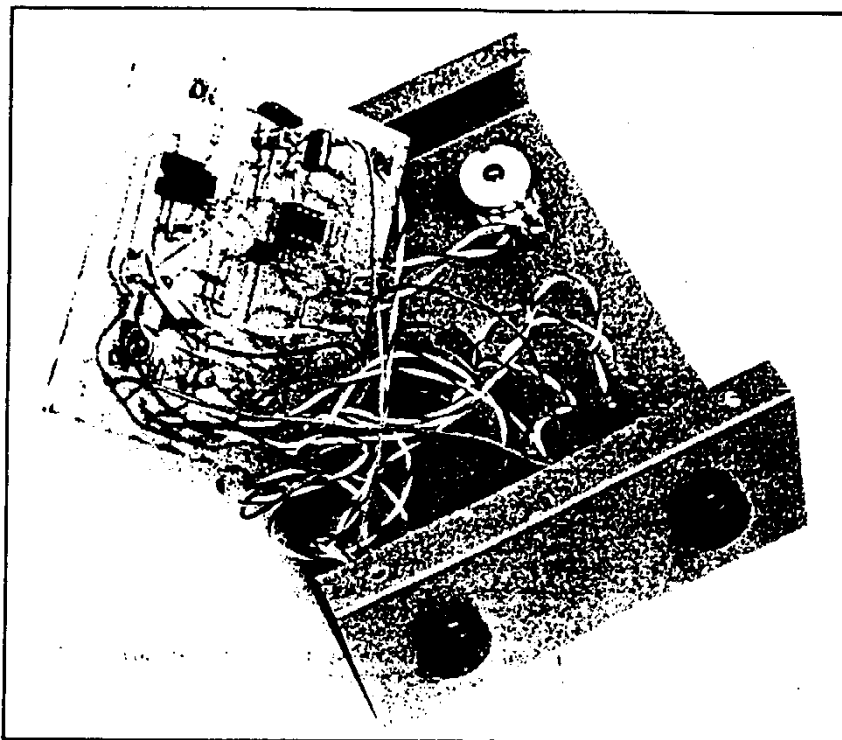

Figure 4. The internal wiring will be neater if sections of 2 and 3-core strip cable are used.

band sweep from bass to treble. Somewhere close to the mid-setting of RV4, the filter acts in a confused manner, giving some very interesting effects, especially to chords. Altering RV3's setting changes the width of the sweep and produces a gentler effect.

However, the most effective way of setting up the unit is to adjust RV2 and RV3 to their minimum rotations. Then, with RV4 set about two-thirds along its travel and RV1 full-on, adjust RV5 until the unit produces a wah-wah sound. Finally, turn back RV5 so that triggering only occurs as you pluck the string. Once this is done, RV1 and RV5 can be left alone while you 'play' with the others.

After getting used to the various control settings, drill holes for the pots,

sockets and footswitch in the case. Our prototype used short 'stand-offs' to secure the PCB. With the unit fully assembled, you can mark the positions of the threshold and bias controls, as necessary. However, the bias control can still be adjusted to produce some weird variations to the basic sound. It's really up to you to discover just how versatile this unit is. It is also possible to alter the basic effect by changing certain component values. For instance, for a less pronounced bass response, change C8 to a smaller value (say 10n). The mid position of RV4 will give different effects if R10 is changed. Lastly, a different filter response will be achieved if the values of C5 and C6 are changed — try 10n for starters.

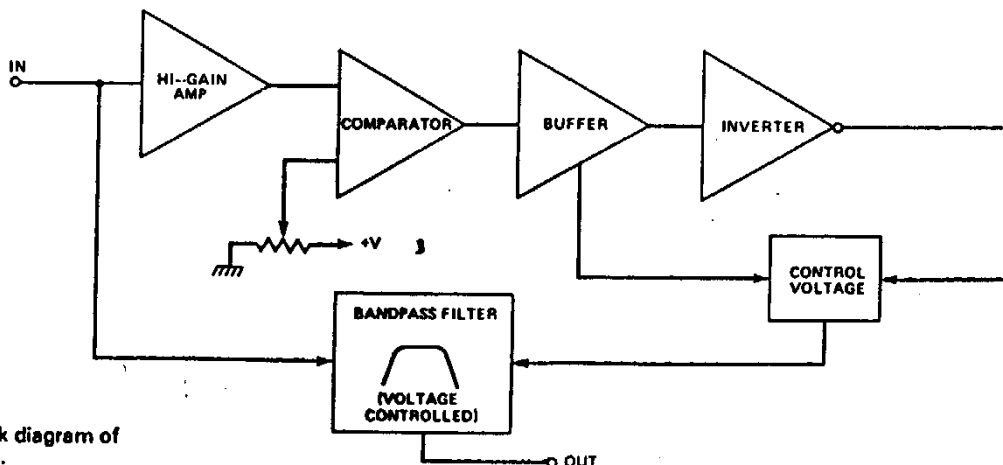

Figure 5. Block diagram of the Auto-Wah.